

□ LV LUGANO

Lavabo de Bajo Cubierta con Rebosadero
Under-deck Washbasin with Overflow

□ LV LUGANO JR

Lavabo de Bajo Cubierta con Rebosadero de 49 x 41 cm
49 x 41 cm Undermount Bathroom Sink

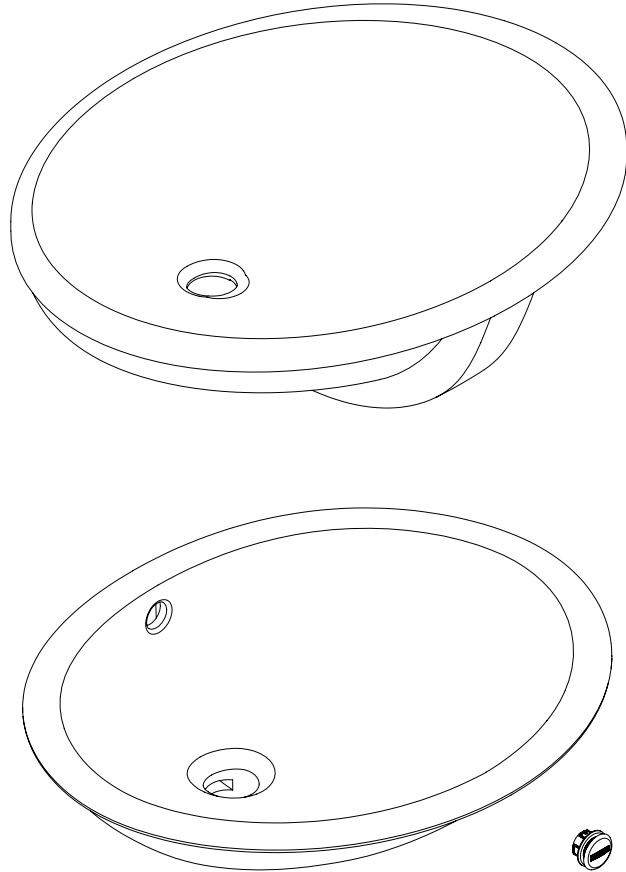

HELVEX®

Garantía de Calidad

Agradecemos su elección por los productos HELVEX. Estamos seguros de que su confiabilidad por el producto excederá sus más altas expectativas, cuya funcionalidad, estética, durabilidad, respaldo integral y alta calidad le otorgarán plena satisfacción por años, reflejando el compromiso con la calidad, innovación y el medio ambiente que forman parte de Helvex.

Thank you for choosing HELVEX products. We are confident that the product reliably will exceed your highest expectations. This product's functionality, aesthetics, durability, quality and support will grant you full satisfaction for years, thus reflecting Helvex's commitment to quality, innovation and the environment.

Esta Guía de Instalación Aplica al Producto en Cualquier Acabado.
This Installation Guide Applies to the Product in any Finishing.

Asesoría y Servicio Técnico
Technical Support and Service
servicio.tecnico@helvex.com.mx
(52) 55 53 33 94 31

Refacciones Originales
Original Spare Parts
refacciones@helvex.com.mx
www.refaccioneshelvex.com.mx
(52) 55 53 33 94 21
(52) 55 53 33 94 00
Ext. 5913, 5068 y 4815
whatsapp 55 8071 7454

Herramientas y Materiales
Requeridos (no incluido)



Required Tools and
Materials (not included)



Información



Information



Lijar
Sand



Advertencia
Warning



Sin fuga
No leakage



Revisar
Review

Acabados: Finishes:
Blanco White





⚠️ **ADVERTENCIA** ⚠️ ⚠️ **WARNING** ⚠️

PRECAUCIÓN: ESTE PRODUCTO ES FRÁGIL. PARA EVITAR ROTURAS Y POSIBLES LESIONES, ¡MANÉJESE CON CUIDADO!

CAUTION: THIS PRODUCT IS FRAGILE. TO AVOID BREAKAGE AND POSSIBLE INJURY, HANDLE WITH CARE!

La sustancia azul de metileno se utiliza en el proceso del aseguramiento de la calidad del producto con el objetivo de asegurar que el producto no presente alguna grieta o fuga. El alcohol isopropílico se utiliza para limpiar el azul de metileno. Estas sustancias no representan ningún daño para la salud del ser humano

The methylene blue substance is used in the quality assurance process of the product in order to ensure that the product does not show any cracks or leaks. Isopropyl alcohol is used to clean methylene blue. These substances are not harmful to human health.

Antes de instalar Before of installation

- Para disminuir el riesgo de lesiones o daños a la propiedad, lea todas las instrucciones antes de instalar el producto.
- Utilice gafas de seguridad.
- En obras de construcción, instalación, modificación, ampliación y reparación deben cumplir con el reglamento de construcción y obras de su localidad.
- El producto ilustrado puede sufrir cambios de aspecto como resultado de la mejora continua a la que está sujeto.

- To reduce the risk of injury or property damage, please read all instructions before installing the product.
- Wear safety glasses.
- For any construction, installation, alteration, extension or repair, comply with your local building codes.
- The product's illustration may vary in appearance to the actual product as result of the continuous improvement process it is subject to.

Problemas, Posibles Causas y Soluciones Troubleshooting

Problema	Causa	Solución
El agua no se va por el rebosadero.	Se instaló una contra sin rebosadero.	Coloque una contra con rebosadero.
Los líquidos se quedan estancados.	Algún elemento obstruye el rebosadero.	Retire el elemento que obstruye.

Problem	Cause	Solution
Water doesn't go through the overflow.	A drain without overflow was installed.	Install a drain with overflow.
Liquids get stuck.	Something is obstructing the overflow.	Remove the obstructing element.

Características del Producto Product Features

- Cerámica de alto brillo porcelanizada.
- Grado de calidad "A".
- Alta resistencia mecánica.
- Esmalte vítreo de alta resistencia
- Instalación con cubiertas de mármol, granito, madera, etc.

- High-gloss vitreous china.
- Quality grade "A".
- High mechanical strength.
- Highly resistant vitreous enamel.
- Installation with marble, granite, wood or other countertops.

Recomendaciones de Limpieza Cleaning Recommendations

Es muy importante seguir las siguientes instrucciones para conservar los acabados de los productos HELVEX con brillo y en perfecto estado:

1. Utilice únicamente agua y un paño limpio.
2. No utilice fibras, polvos, abrasivos, ni productos químicos.
3. No utilice objetos punzo-cortantes para limpiar los acabados.
4. Se recomienda realizar la limpieza de su producto diariamente.

Visite nuestras páginas www.helvex.com.mx para México y www.helvex.com para el mercado Internacional.

It is very important to follow the instructions below to preserve HELVEX products finishings shiny and in perfect conditions:

1. Use only water and a clean cloth.
2. Do not use fibers, powders, abrasives, or chemicals.
3. Do not use sharp objects to clean the finishings.
4. It is recommended to clean your device daily.

Visit our websites www.helvex.com.mx for México and www.helvex.com for the international market.



Medidas de Instalación



Installation Dimensions

* Medidas Recomendadas
* Recommended Dimensions

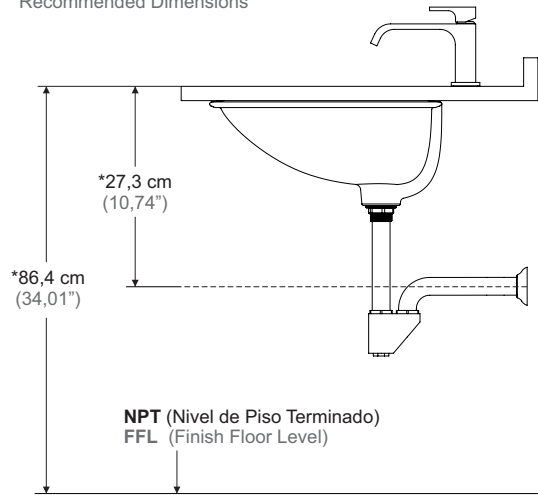

* Medidas Recomendadas
* Recommended Dimensions

Modelo Model	A	B	C
LV LUGANO	6,3 cm 2,48"	37,9 cm 14,92"	44,6 cm 17,55"
LV LUGANO JR	8,3 cm 3,25"	33,3 cm 13,11"	40,8 cm 16,07"

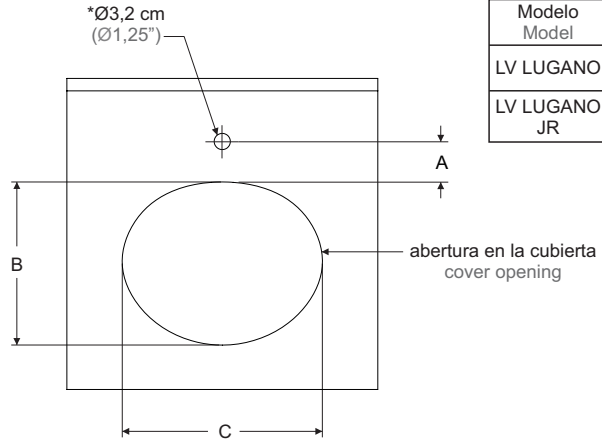

Instalación



Installation



- 1 Para cubiertas sin apertura, y de madera o similar, realice lo siguiente:
For countertops without opening, and wooden or similar, do the following:

