

- E-300**
- E-300-EB**
Monomando para Fregadero
Kitchen Sink Faucet

- E300-6**
Monomando para Fregadero, 6,0 LPM
Kitchen Sink Faucet, 1,58 GPM



garantía de calidad

Agradecemos su elección por los productos HELVEEX. Estamos seguros de que su confiabilidad por el producto excederá sus más altas expectativas, cuya funcionalidad, estética, durabilidad, respaldo integral y alta calidad le otorgarán plena satisfacción por años, reflejando el compromiso con la calidad, innovación y el medio ambiente que forman parte de Helvex.

Thank you for choosing HELVEEX products. We are confident that the product reliably will exceed your highest expectations. This product's functionality, aesthetics, durability, quality and support will grant you full satisfaction for years, thus reflecting Helvex's commitment to quality, innovation and the environment.

Esta Guía de Instalación Aplica al Producto en Cualquier Acabado.
This Installation Guide Applies to the Product in any Finishing.

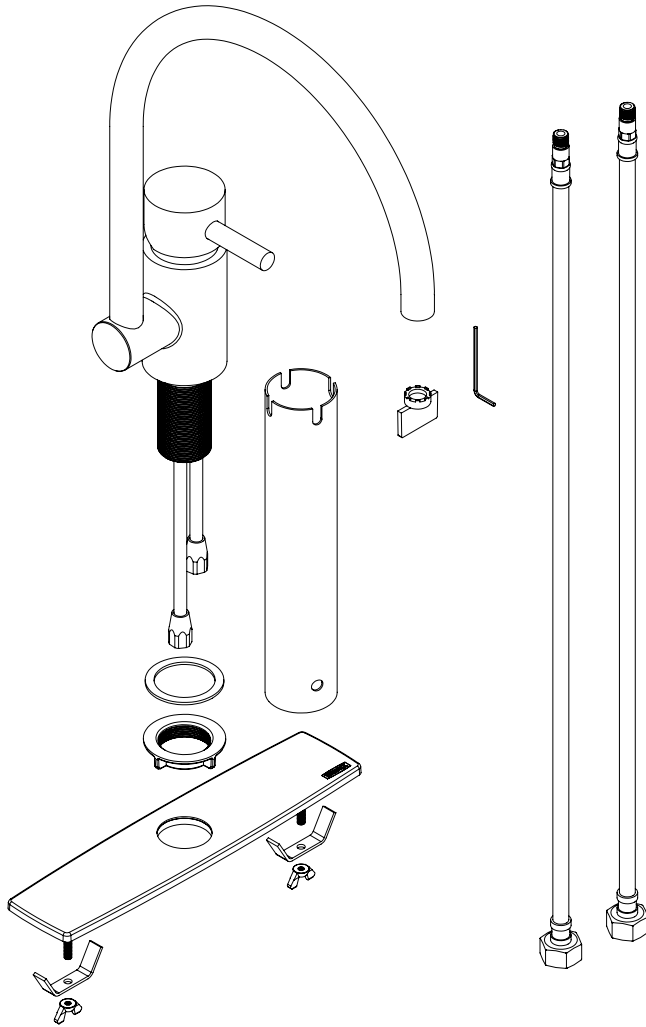

Asesoría y Servicio Técnico
Technical Support and Service
servicio.tecnico@helvex.com.mx
(52) 55 53 33 94 31

Refacciones Originales
Original Spare Parts
refacciones@helvex.com.mx
www.refaccioneshelvex.com.mx
(52) 55 53 33 94 21
(52) 55 53 33 94 00
Ext. 5913, 5068 y 4815
whatsapp 55 8071 7454

Cumplimiento Normativo

Hoja de Especificación

Herramientas y
Materiales Requeridos



Required Tools
and Materials

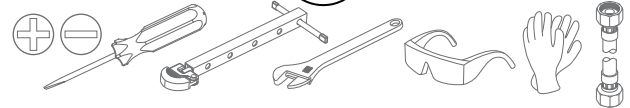

Información



Information



Refacción
Spare Part



Reensamblar
Reassemble



Revisar
Review



Caliente
Hot



Manualmente
By hand



Sin fuga
No leakage



Frio
Cold



Acabados: Finishes:
Cromo Chrome
EB Ébano Matte Black



Requerimientos de Instalación Installation Requirements

Para el correcto funcionamiento de estos productos, se recomiendan las siguientes presiones:

For the correct functioning of these products, the recommended water pressures are:

Modelo Model:	Mínima Minimum			Máxima Maximum		
	kg/cm ²	PSI	kPa	kg/cm ²	PSI	kPa
E-300 E-300-EB E300-6	0,25	3,55	24,51	6,0	85,3	558,3

Antes de instalar Before of installation

- Para disminuir el riesgo de lesiones o daños a la propiedad, siga todas las instrucciones antes de instalar el producto.
- Utilice gafas de seguridad.
- En obras de construcción, instalación, modificación, ampliación y reparación deben cumplir con el reglamento de construcción y obras de su localidad.
- El producto ilustrado puede sufrir cambios de aspecto como resultado de la mejora continua a la que está sujeto.

- To reduce the risk of injury or property damage, please follow all instructions before installing the product.
- Wear safety glasses.
- For any construction, installation, alteration, extension or repair, comply with your local building codes.
- The product's illustration may vary in appearance to the actual product as result of the continuous improvement process it is subject to.

Problemas, Posibles Causas y Soluciones Troubleshooting

Problema	Causa	Solución
No sale agua.	La válvula de alimentación principal está cerradas.	Abra la válvula de alimentación principal de agua.
	La palanca se encuentra cerrada.	Jale y/o gire el maneral según la operación del producto.
Poco flujo de agua.	El aireador esta obstruido.	Realice mantenimiento al aireador.
	La presión de operación no es la adecuada.	Verifique la presión en los requerimientos de instalación.
	Las válvulas angulares no están totalmente abiertas.	Abrir totalmente las válvulas angulares.
La salida está floja.	La tuerca no está apretada.	Apriete firmemente la tuerca.
Fuga en las conexiones.	Las conexiones no están apretadas.	Apriete las conexiones.

Problem	Cause	Solution
No water flow.	The main water supply valve is closed.	Open the water supply valve.
	The lever handle is closed.	Pull and/or turn the handle, according to the product operation.
Little water flow.	The aerator is clogged.	Perform aerator maintenance.
	Operating pressure is not adequate.	Verify the pressure in the installation requirements.
	Angular valves are not fully open.	Fully open angle valves.
The single handle sink faucet is loose.	The nut is not tightened.	Tighten the nut.
Leaks in the connections.	The connections aren't tight.	Tighten the connections.

Recomendaciones de Limpieza Cleaning Recommendations

Es muy importante seguir las siguientes instrucciones para conservar los acabados de los productos HELVEX con brillo y en perfecto estado:

1. Utilice únicamente agua y un paño limpio.
2. No utilice fibras, polvos, abrasivos, ni productos químicos.
3. No utilice objetos punzo-cortantes para limpiar los acabados.
4. Se recomienda realizar la limpieza de su producto diariamente.

Visite nuestras páginas www.helvex.com.mx para México y www.helvex.com para el mercado Internacional.

It is very important to follow the instructions below to preserve HELVEX products finishings shiny and in perfect conditions:

1. Use only water and a clean cloth.
2. Do not use fibers, powders, abrasives, or chemicals.
3. Do not use sharp objects to clean the finishings.
4. It is recommended to clean your device daily.

Visit our pages www.helvex.com.mx for Mexico and www.helvex.com for the International market.

Medidas de Instalación



Installation Dimensions

* Medidas Recomendadas
* Recommended Dimensions

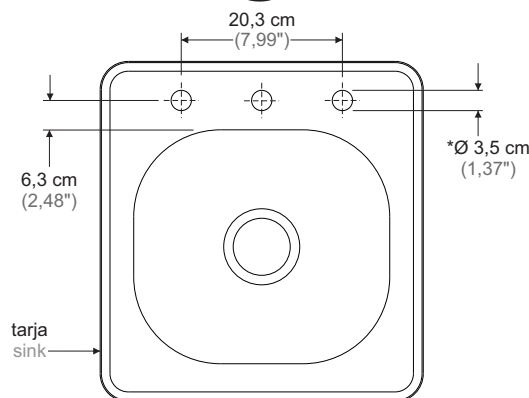

Instalación

Installation

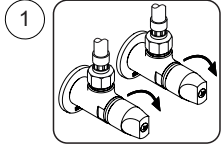
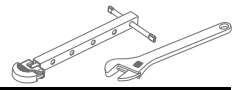

2

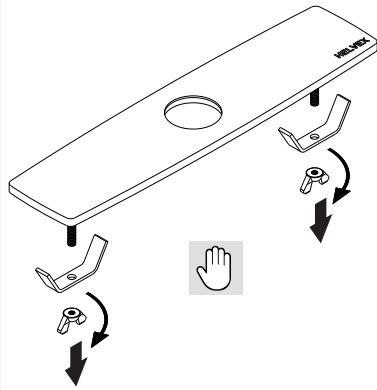

3

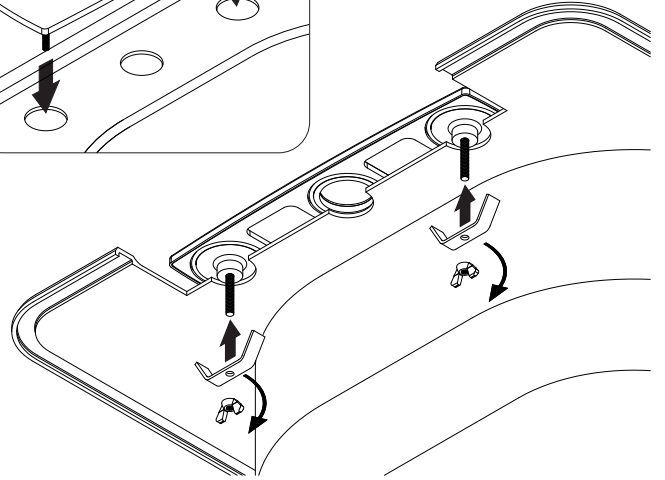
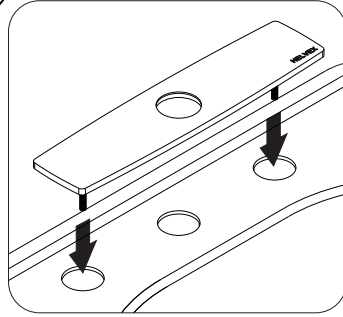

4

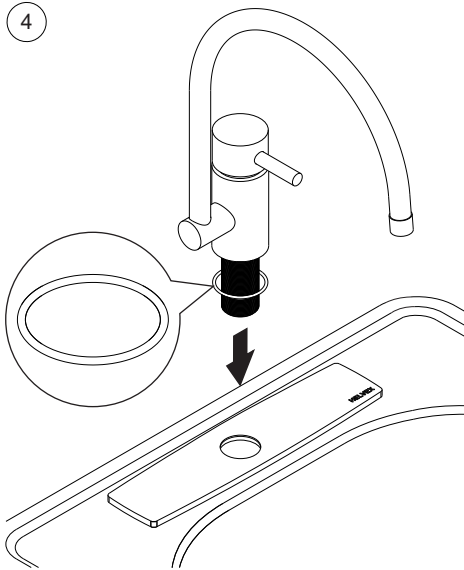

6

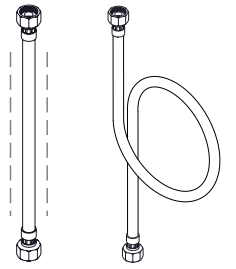
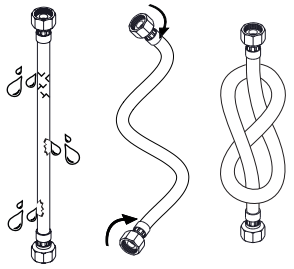
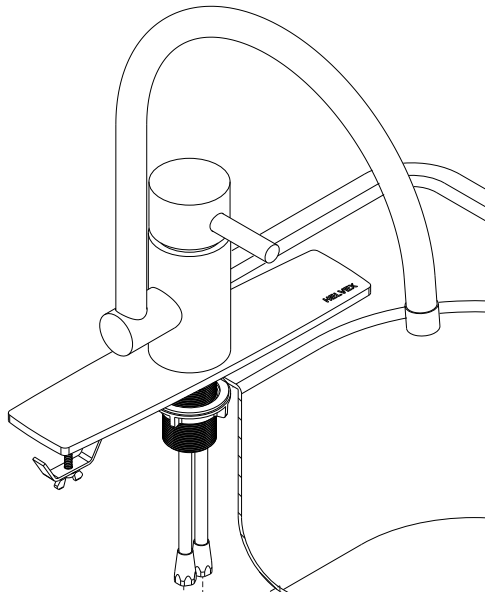

5

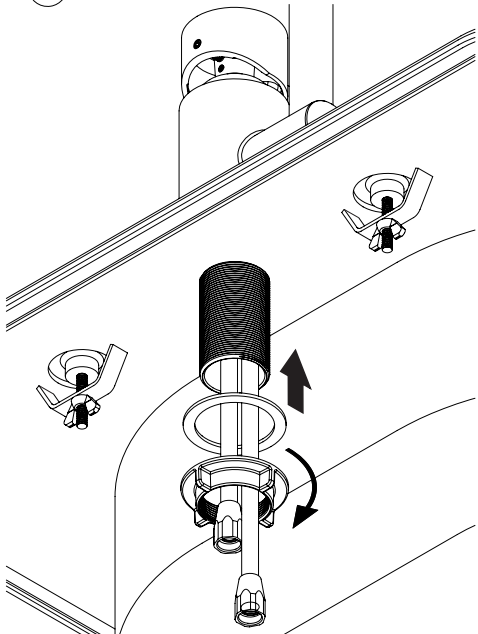

Operación

Operation



7

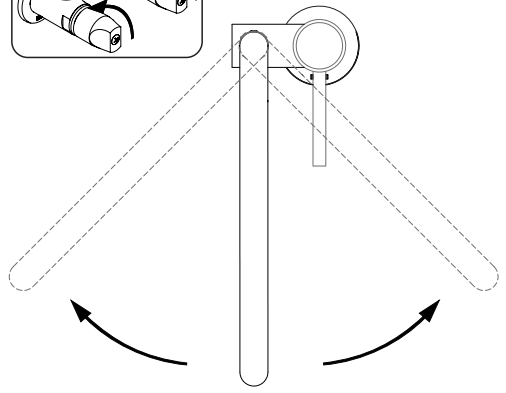
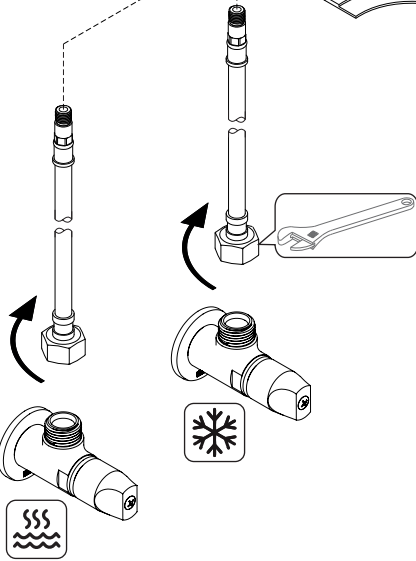
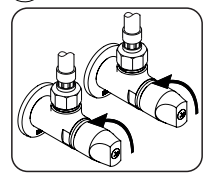

Operación



Operation

8

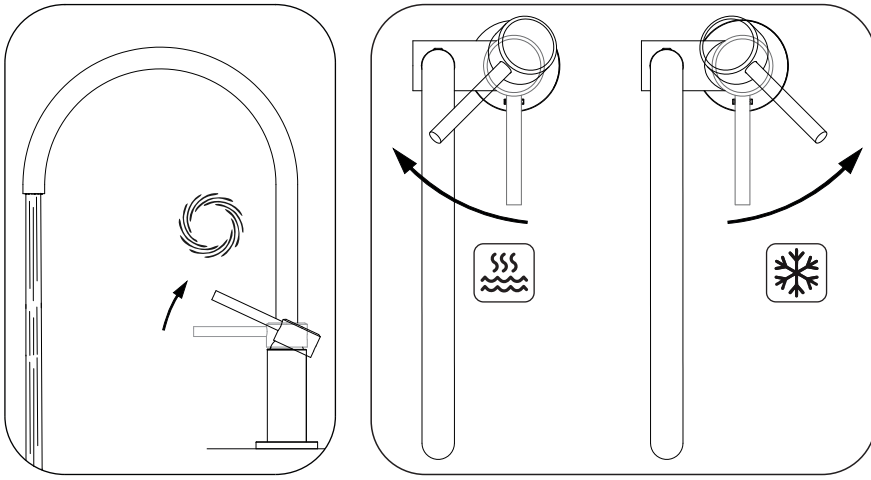

Mantenimiento del Economizador



Flow Restrictor Maintenance

9

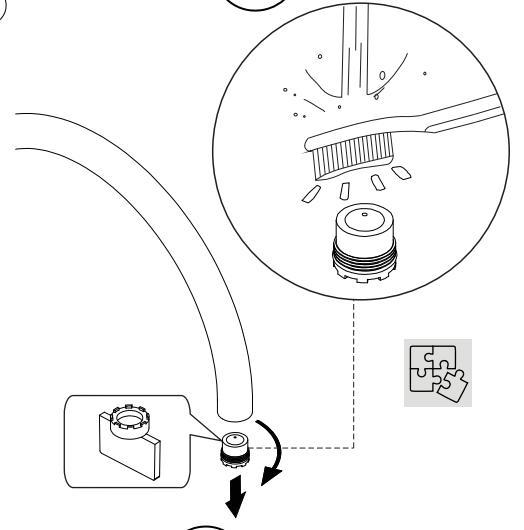

Mantenimiento del Cartucho



Cartridge Maintenance

10

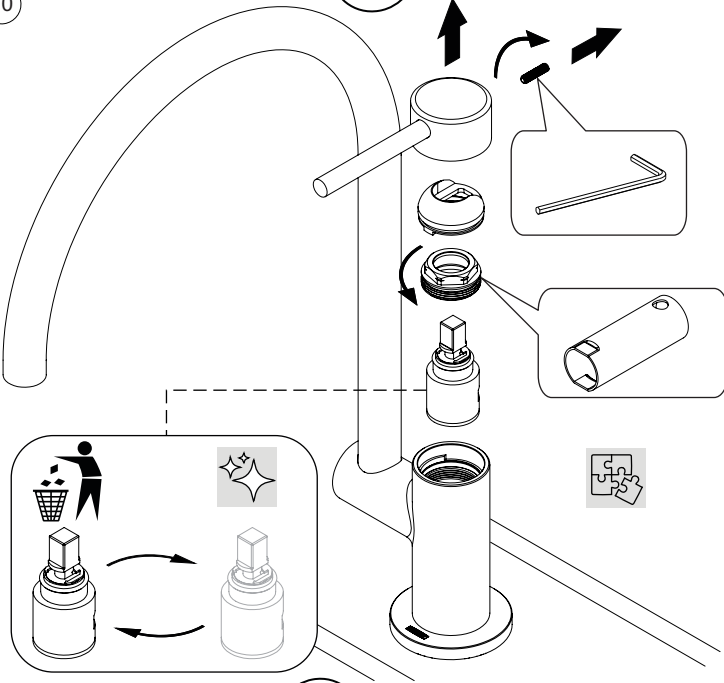

Mantenimiento del Cuello



Gooseck Maintenance

11

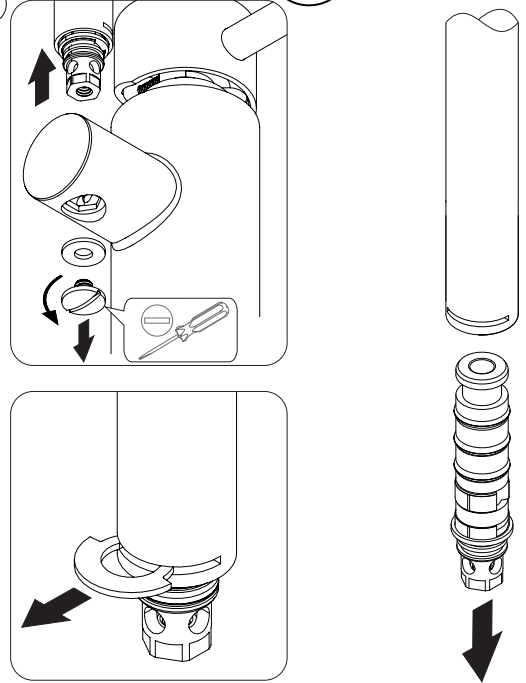

Mantenimiento del Cuello



Gooseck Maintenance

12

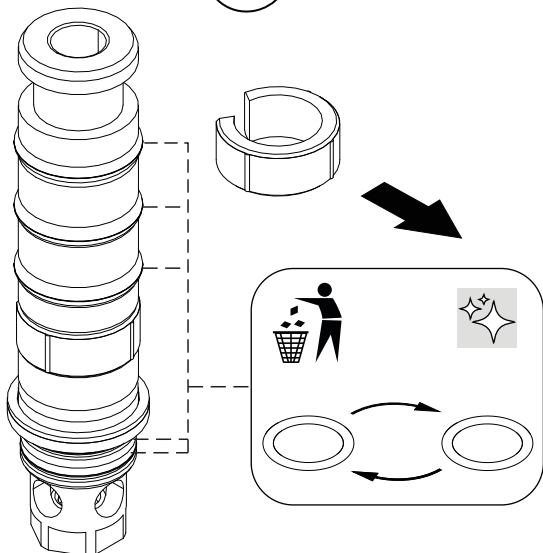

Limpieza



Cleaning

13

