

Spiga

SPG-100

SPG-100-EB

Monomando para Lavabo sin Contra
Single Handle Sink Faucet without Drain

SPG-101

SPG-101-EB

Monomando Alto para Lavabo sin Contra
High Single Handle Sink Faucet without Drain



Garantía de Calidad

Agradecemos su elección por los productos HELVEEX. Estamos seguros de que su confiabilidad por el producto excederá sus más altas expectativas, cuya funcionalidad, estética, durabilidad, respaldo integral y alta calidad le otorgarán plena satisfacción por años, reflejando el compromiso con la calidad, innovación y el medio ambiente que forman parte de Helvex.

Thank you for choosing HELVEEX products. We are confident that the product reliably will exceed your highest expectations. This product's functionality, aesthetics, durability, quality and support will grant you full satisfaction for years, thus reflecting Helvex's commitment to quality, innovation and the environment.

Esta Guía de Instalación Aplica al Producto en Cualquier Acabado.
This Installation Guide Applies to the Product in any Finish.

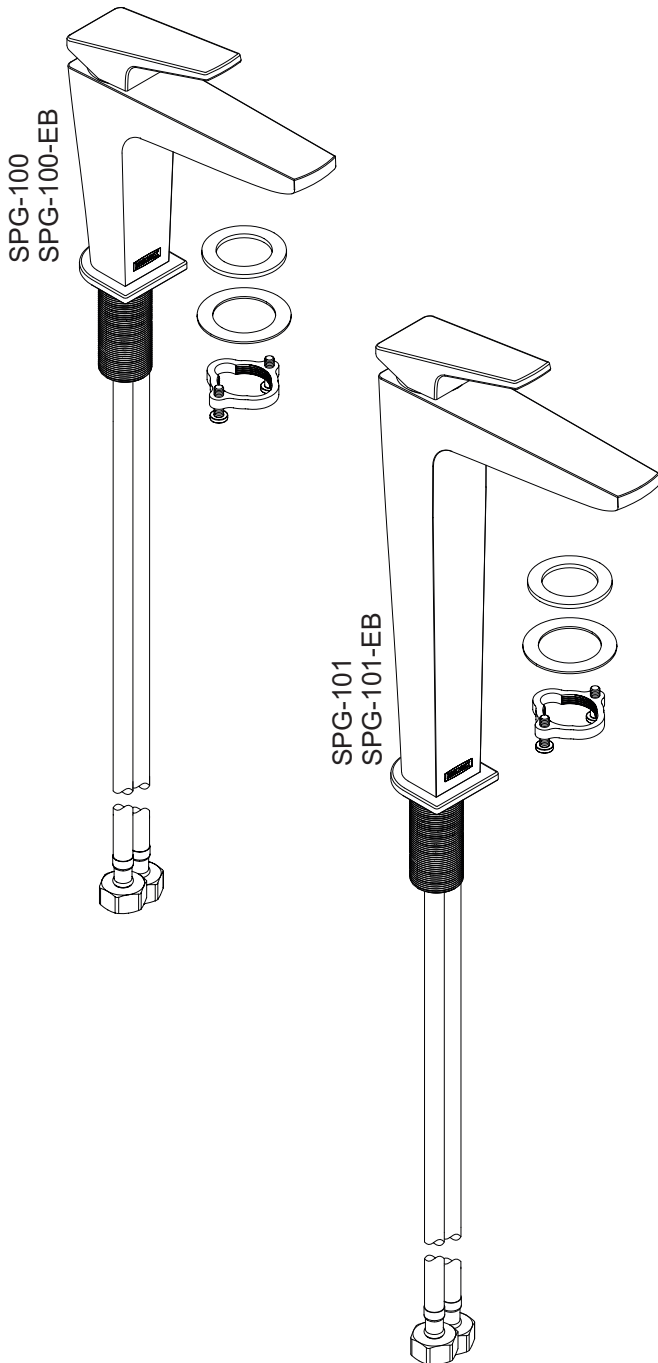

Asesoría y Servicio Técnico
Technical Support and Service
servicio.tecnico@helvex.com.mx
(52) 55 53 33 94 31

Refacciones Originales
Original Spare Parts
refacciones@helvex.com.mx
www.refaccioneshelvex.com.mx
(52) 55 53 33 94 21
(52) 55 53 33 94 00
Ext. 5913, 5068 y 4815
whatsapp 55 8071 7454

Herramientas y Materiales Requeridos (No Incluidos)	Required Tools and Materials (Not Included)
2,5 mm 1,0"	\$
Información	Information
Purgar Purgue	Reensamblar Reassemble
Manualmente By hand	Sin fuga No leakage
	Refacción Spare Part
	Revisar Review
	Caliente Hot
	Frío Cold

Acabados: Finishes:
Cromo Polished Chrome
EB Ébano Matte Black

HECHO EN CHINA
MADE IN CHINA





Requerimientos de Instalación Installation Requirements

Para el correcto funcionamiento de estos productos, se recomiendan las siguientes presiones:

For the correct functioning of these products, the recommended water pressures are:

Modelo Modelo	Minimum Mínima			Maximum Máxima		
	kg/cm ²	PSI	kPa	kg/cm ²	PSI	kPa
SPG-100, SPG-100-EB	1,0	14,22	98,06	6,0	85,34	588,39
SPG-101, SPG-101-EB						

Antes de Instalar Before of Installation

- Para disminuir el riesgo de lesiones o daños a la propiedad, siga todas las instrucciones antes de instalar el producto.
- Utilice gafas de seguridad.
- En obras de construcción, instalación, modificación, ampliación y reparación deben cumplir con el reglamento de construcción y obras de su localidad.
- El producto ilustrado puede sufrir cambios de aspecto como resultado de la mejora continua a la que está sujeto.
- To reduce the risk of injury or property damage, please follow all instructions before installing the product.
- Wear safety glasses.
- For any construction, installation, alteration, extension or repair, comply with your local building codes.
- The product's illustration may vary in appearance to the actual product as result of the continuous improvement process it is subject to.

Problemas, Posibles Causas y Soluciones Troubleshooting

Problema	Causa	Solución
No sale agua.	Las válvulas de alimentación principal están cerradas.	Abra las válvulas de alimentación principal de agua.
	La palanca se encuentra cerrada.	Jale y/o gire el maneral según la operación del producto.
Poco flujo de agua.	La presión de operación no es la adecuada.	Verifique la presión en los requerimientos de instalación.
	Las válvulas angulares no están totalmente abiertas.	Abrir totalmente las válvulas angulares.
La salida está floja.	La tuerca no está apretada.	Apriete firmemente la tuerca.
Fuga en las conexiones.	Las conexiones no están apretadas.	Apriete las conexiones.

Problem	Cause	Solution
No water flow.	The main water supply valves are closed.	Open the water supply valves.
	The lever handle is closed.	Pull and/or turn the handle, according to the product operation.
Little water flow.	Operating pressure is not adequate.	Verify the pressure in the installation requirements.
	Angle valves are not fully open.	Fully open angle valves.
The single handle sink faucet is loose.	The nut is not tightened.	Tighten the nut.
Leaks in the connections.	The connections aren't tight.	Tighten the connections.

Recomendaciones de Limpieza Cleaning Recommendations

Es muy importante seguir las siguientes instrucciones para conservar los acabados de los productos HELVEX, con brillo y en perfecto estado:

1. Utilice únicamente agua y un paño limpio.
 2. No utilice fibras, polvos, abrasivos, ni productos químicos.
 3. No utilice objetos punzo-cortantes para limpiar los acabados.
 4. Se recomienda realizar la limpieza de su producto diariamente.
- Visite nuestras páginas www.helvex.com.mx para México y www.helvex.com para el mercado Internacional.

It is very important to follow the instructions below to preserve HELVEX products finishes, shiny and in perfect condition:

1. Use only water and a clean cloth.
2. Do not use fibers, powders, abrasives, or chemicals.
3. Do not use sharp objects to clean the finishes.
4. It is recommended to clean your product daily.

Visit our pages www.helvex.com.mx for Mexico and www.helvex.com for the International market.





1

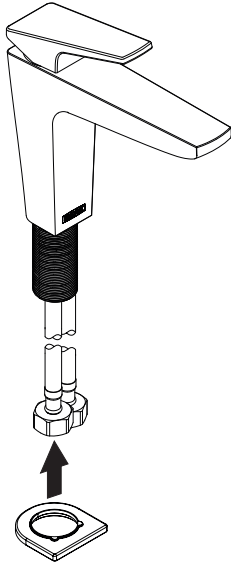
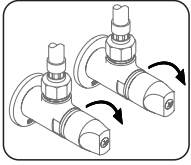

2

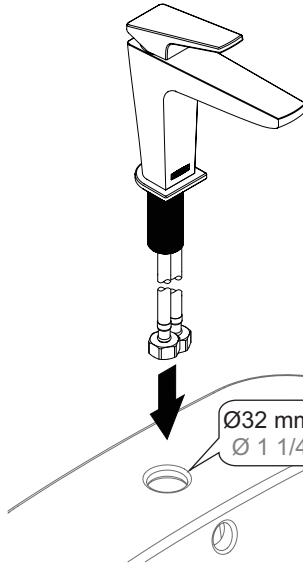

Ø32 mm - 38 mm máx.
Ø 1 1/4" - 1 1/2" max.

3

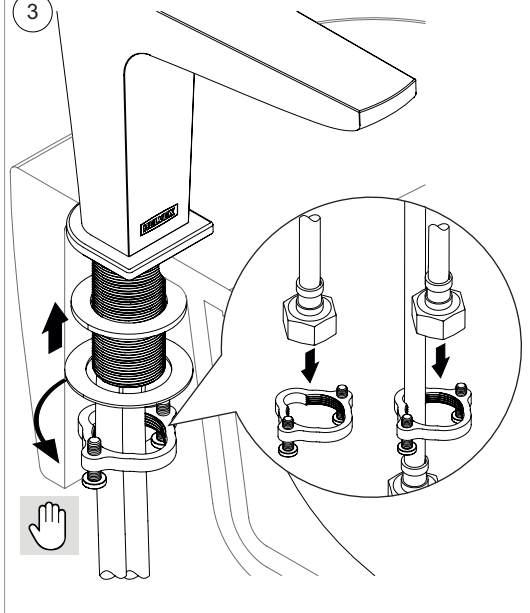

4

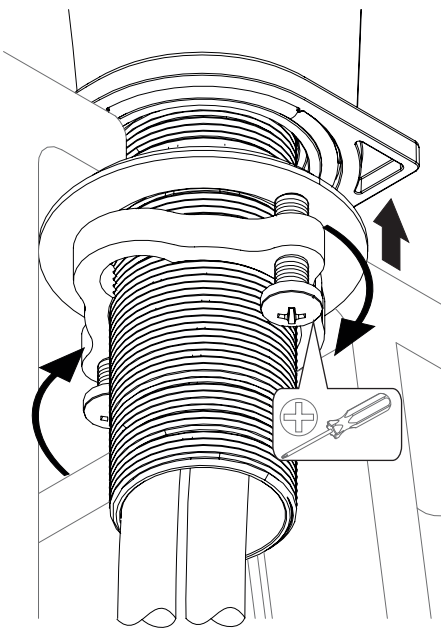

5

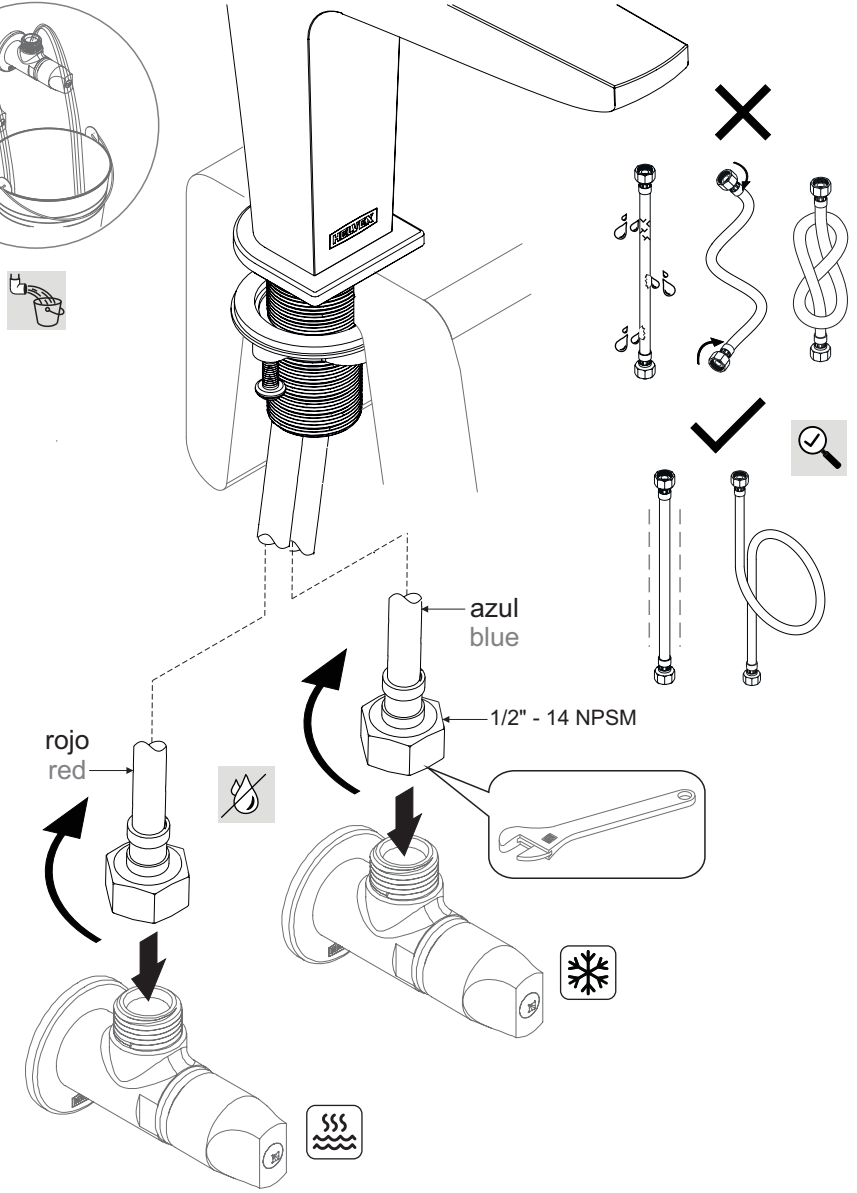
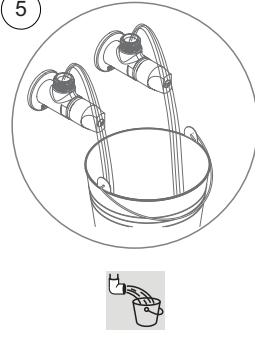

rojo red

azul blue

1/2" - 14 NPSM

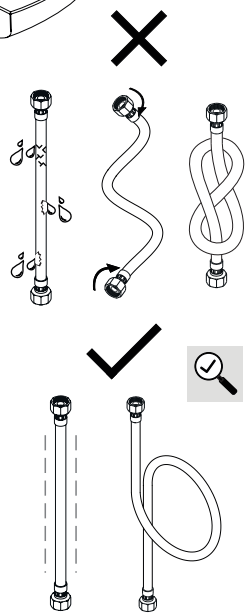

Operación

Operation

6

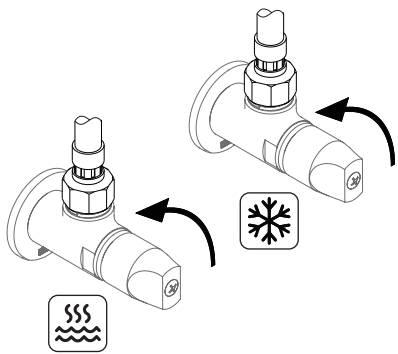

7

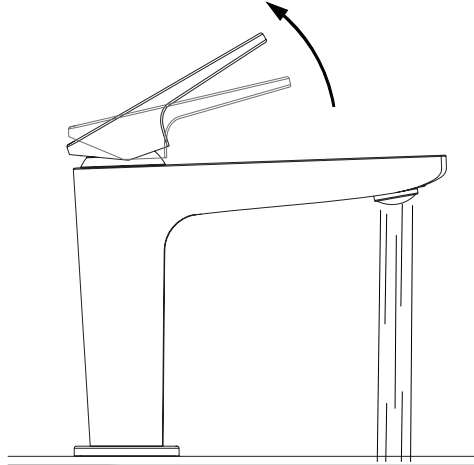

8

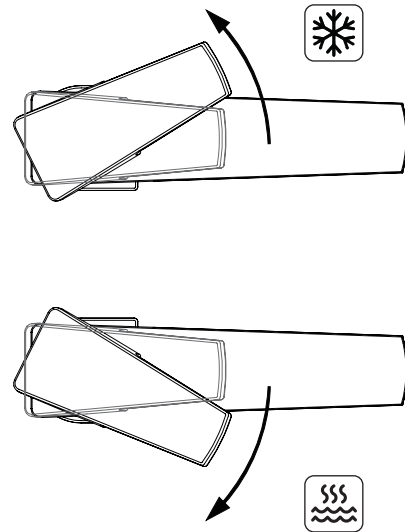

Mantenimiento del Aireador

Aerator Maintenance



9

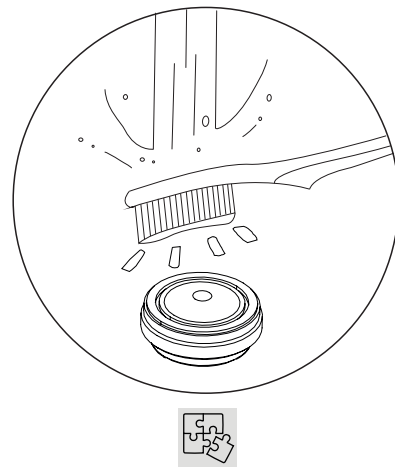
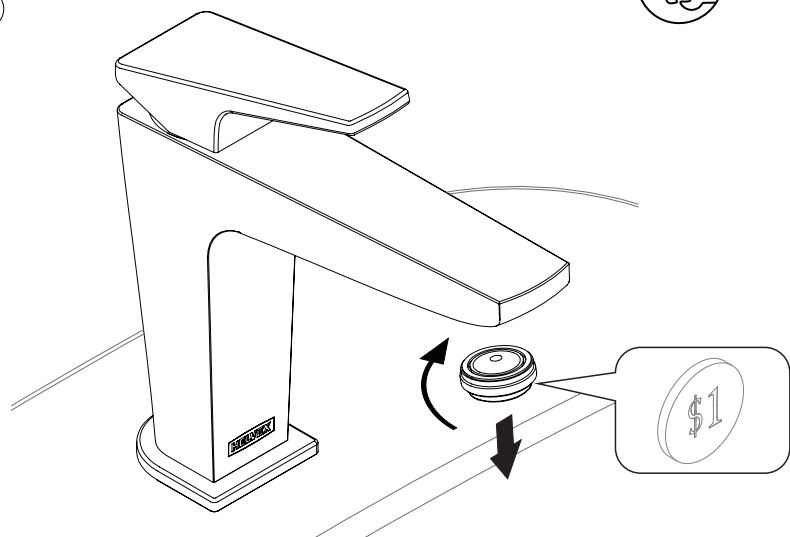

Mantenimiento del Cartucho

Cartridge Maintenance



10

